

# Owner's Manual and Safety Guide



Thank you for allowing Whittier Wood Furniture to help you furnish your home. We are certain you will be delighted with your new furniture. Please take a few minutes to read this Owner's Manual and Safety Guide. It contains very important safety information as well as details on certain features, functions and care tips of your furniture.



## Safety First! Anchor It!



### Reduce the Risk of Furniture Tipovers:

Whittier Wood Furniture engineers and manufactures product to facilitate the reduction of injuries or death from furniture tipovers. Each chest or dresser includes a Tipping Restraint and Anti-tip drawer interlock mechanism. The furniture owner is **STRONGLY** advised to attach the Tipping Restraint as noted in our instructions and follow all other safety recommendations outlined.

### “NO HOLES IN THE WALL”

#### Tipping Restraint:

Whittier has developed a unique system that makes it very easy to anchor our furniture. A high strength polypropylene strap is attached at the base of designated furniture. The other end anchors below the baseboard. Please follow the complete instructions in the Tipping Restraint Kit attached to the bottom of your unit. If you cannot locate the restraint, please contact us for immediate replacement. **Not all products require a tipping restraint.** Please consult the parts list of the Assembly Instructions included in this guide.

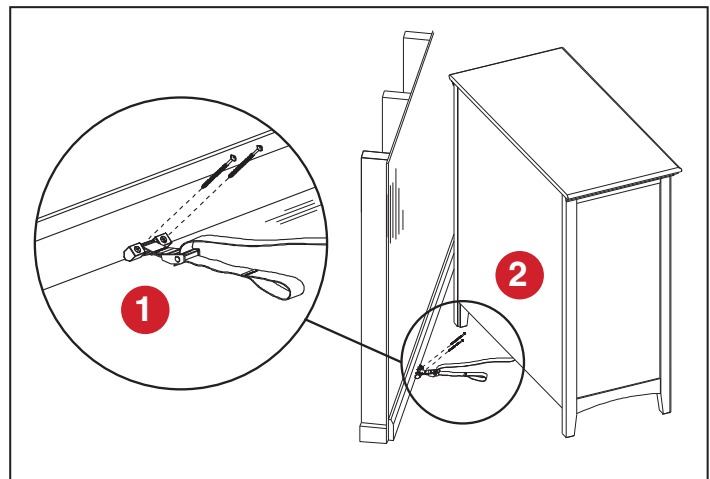

- 1 NO HOLES IN THE WALL.** Easily attaches with two screws to the bottom plate of the wall or sub-floor sheathing.
- 2** High strength polypropylene strap already attached to the furniture.

### For Questions or Replacement Tipping Restraint:

**Customer Service:** 800-653-3336 • **Outside the U.S. or Canada:** 541-687-0213

**Fax:** 541-687-2060 • **Email:** [Info@whittierwood.com](mailto:Info@whittierwood.com)

3787 West 1st Avenue • P.O. Box 2827 • Eugene, Oregon • USA 97402 • [whittierwood.com](http://whittierwood.com)

**NOT TO BE REMOVED EXCEPT BY THE CONSUMER**

## Drawer Removal and Installation

Chests and Dressers include an Anti-Tip drawer interlock safety mechanism allowing only one locked drawer per vertical bank of drawers to be opened at a time. See below.

- **Removal:** Pull up on the left Drawer Release Lever while pushing down on the right Drawer Release Lever and pull out the drawer, see Fig. 1. Note where each drawer came from to make sure you place them back into their correct positions. Drawers are numbered on the bottom or back of the drawers.
- **Installation:** Fully extend the movable portion of the slides from the side of the case, see Fig. 2. Carefully align the drawer slides with the extended case slides and slowly insert the drawer. Check to be sure the drawer slides have not slipped out of the cabinet slides. About 3" from closure you may encounter some resistance. Check for alignment again and if everything is alright, push through the resistance.

### Helpful hints for installation:

- Go slow. Be patient.
- Keep an eye on the drawer slides to make certain they do not slip out of the tracks.
- You can expect to encounter resistance when the drawer is about 3" from being all the way closed. Check the slides for alignment again then push through the resistance.

Fig. 1

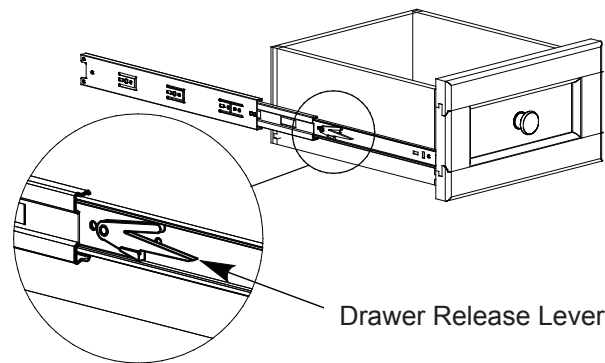
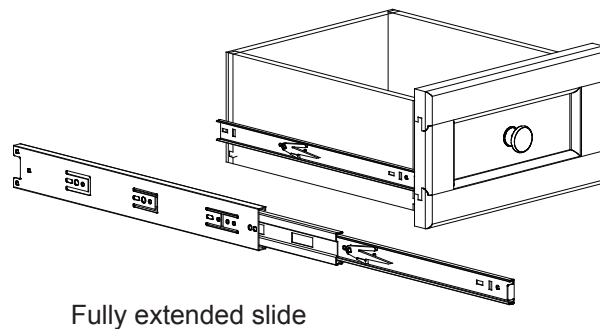

Fig. 2



## Anti-Tip Drawer Interlock Safety Mechanism

The drawer interlock system has two major parts; drawer clips attached to the sides of the drawers and anti-tip snapper arms attached to the side panels as shown in Figure A. If you want to remove more than one of the secured drawers, you have to change the position of the snapper arm to ensure it is unlocked.

When you open a secured drawer, the snapper arm will be angled forward. See Figure B. Remove the drawer. Push the snapper arm back so it is straight. See Figure C. Now you can remove another drawer adjacent to the one already removed. Be sure to install the drawer in the original position.

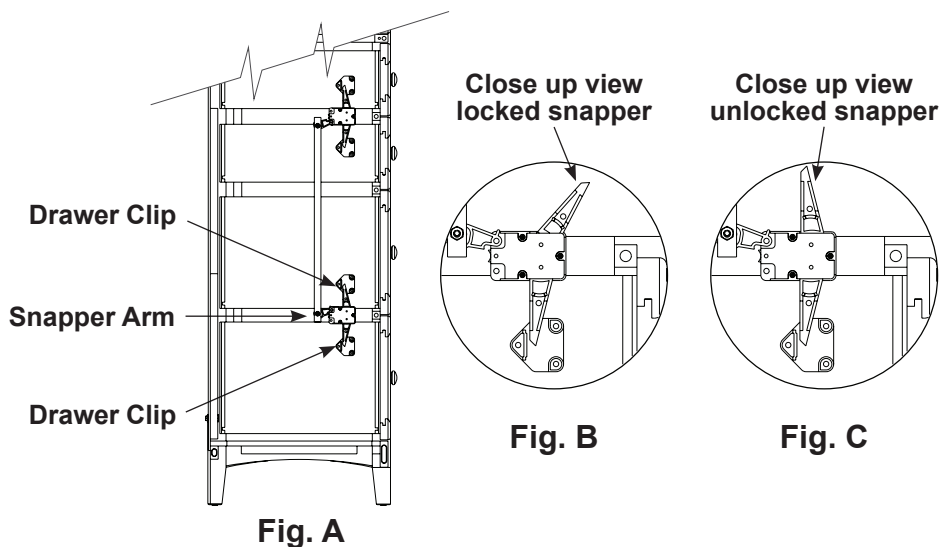

## Adjustable Glides

Beds, wide dressers and media consoles need to have the center foot or feet SUPPORTING the weight of the furniture. Please make sure to adjust the glides according to the instructions.

Adjustable Glides come preinstalled and are also useful for leveling your furniture. Please refer to the assembly instructions for more detailed information.

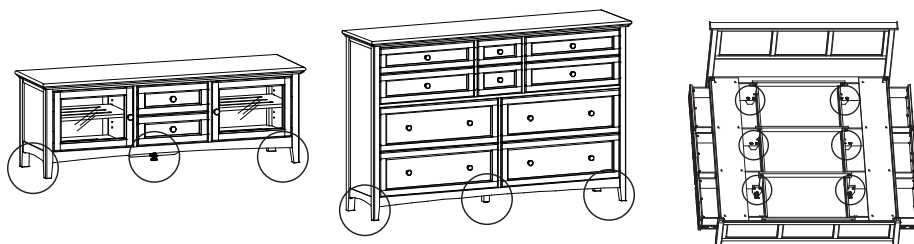

On each leg and center foot/feet

Under bed frame

## Furniture Care

Your Whittier Wood Furniture piece has been created so it will last for many years to come. Our construction methods are of the highest quality and we only use solid hardwood or veneered hardwood.

Wood can be susceptible to changing color over time when exposed to strong sunlight. Use window shades, drapes or blinds to protect your furniture. To help the surface age evenly and avoid dark and light spots, periodically move items to expose the entire surface to an even amount of light so it may develop a uniform patina.

Today's modern finishes require less maintenance than in years past. Our finishes resist most liquids and heat for up to 24 hours. Here are some simple tips to maintain your furniture.

- Dust with a soft cloth slightly dampened with water. Wipe in the direction of the wood grain.

- Fingerprints and greasy smears can be removed with a solution of 1 part white vinegar to 4 parts water.
- If you would rather use a commercial product Simple Green® will not damage the finish. A final wipe with clean water and a soft cloth is recommended.
- To prevent scratching, use felt discs under lamps or accessories that are placed on the furniture.
- If you choose to use glass on top of wood, use discs between the glass and the wood to allow air circulation.
- Please do not use cleaning products with ammonia or silicone base.
- Use of waxes and polishes are not recommended because they can leave a residue that could dull the finish over time.

## Options to Touch Up Your Finish

We recommend first contacting the dealer where you made your purchase. They often have a local contact experienced in repairs. Repairing finishes is a multi-step process best done by experienced technicians.

For minor repairs on our finishes, we can recommend Mohawk Brush Tip®, Mohawk Fil-Stik® and/or Blendal® Stick. These are available at [www.mohawkconsumerproducts.com/products/wood](http://www.mohawkconsumerproducts.com/products/wood).

### Finish: Compatible colors by Mohawk Finishing Products®

Whittier Finish	Mohawk Brush Tip® Marker	Mohawk Finishing FIL-STIK®
Glazed Antique Cherry (GAC)	Perfect Brown - M265-2002	Burnt Umber - M340-0003
Java (JAV)	Perfect Brown - M265-2002	Dark Walnut - M340-0035
Fieldstone (FST)	In House Fill Pen**	Grey Loft - M230-111654
Snowbound (SN)	In House Fill Pen**	White - M230-0202
DUET (Walnut)	Perfect Brown - M265-2002	Dark Walnut - M340-0035
DUET (NA)	Warm Oak Tone - M265-2018	Honey Spice - M230-4016
Pecan (PEC)*	Natural Light Oak - M265-2017	Sandlewood - M231-8652

\*Pecan is also compatible with **Mohawk Blendal Stick® Mocha** - M340-0040

\*\* Please contact Whittier Customer Service for In House Fill Pen.

## Limited Warranty

As a family owned and operated company we are committed to making a quality product as if we were making it for ourselves.

Whittier Wood Furniture warrants to the original purchaser that our furniture and all its parts and components are free of defects in material and workmanship. If you find a defect in material or workmanship, Whittier Wood Furniture will replace the part free of charge. "Defects" as defined in this warranty, are any imperfection in material or workmanship that will impair the use of the furniture product. Our warranty is expressly limited to the replacement of furniture parts and/or components.

Whittier Wood Furniture's limited warranty is for two years from date of purchase and is limited to the original purchaser. In addition, we will work with the retailer where the item was purchased if repairs are needed. In no event shall Whittier Wood Furniture be liable for damages resulting from the use of the product.

### This limited warranty does not cover:

- 1) Defects occurring after purchase due to product modification, intentional damage, accident, misuse, abuse, or negligence.
- 2) Freight or handling damage
- 3) Normal wear and tear due to age
- 4) Labor or assembly costs

## Customer Service

If at any time you should have a question please contact our Customer Service Department. Our website also contains product information you may find helpful.

**Monday-Friday 8:00a.m. to 5:00p.m. PT.**

You may leave a message 24 hours a day, seven days a week.

**Phone:** 800-653-3336 • **Outside the U.S. or Canada:** 541-687-0213 • **Fax:** 541-687-2060

**Email:** [Info@whittierwood.com](mailto:Info@whittierwood.com) • [whittierwood.com](http://whittierwood.com) • P.O. Box 2827, Eugene, Oregon 97402, U.S.A.

# Safety First! Anchor It!

## And Protect A Child

According to the U.S. Consumer Product Safety Commission an estimated **11,300** children under the age of 18 were treated in U.S. hospital emergency rooms for TV, furniture and appliance related tip-over injuries from 2017 to 2019. Most of these injuries could have been prevented by just using a tipping restraint.

**For more information: [www.AnchorIt.gov](http://www.AnchorIt.gov)**

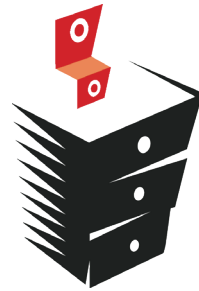

# Anchor It!

Secure Furniture and TVs:  
Protect Children

## Three Easy Steps

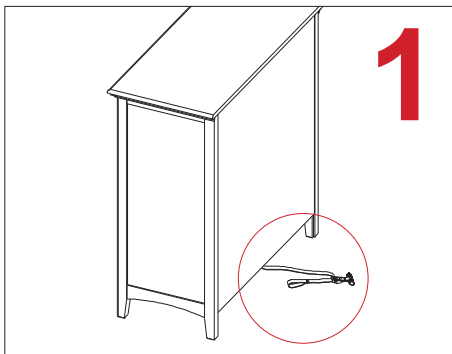

Locate the tipping strap attached to the furniture.

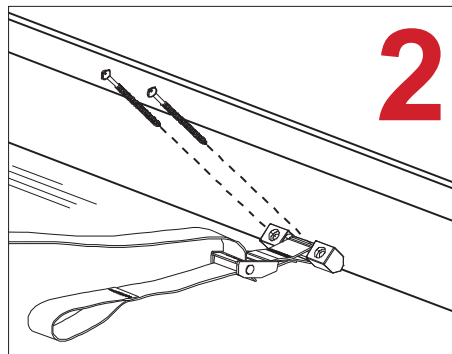

Loosen the strap and attach the bracket at a 45° angle under the baseboard in the desired location.

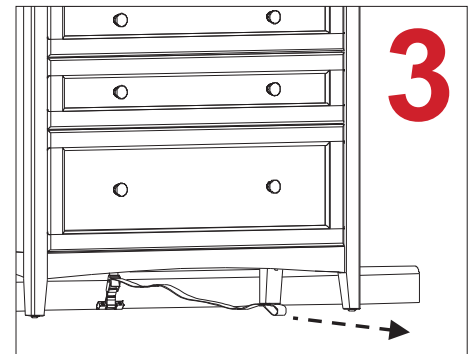

Push furniture against the wall and reach underneath to grasp the loop. Pull the loop end until tight.

## ! WARNING



**Children have died from furniture tipover. To reduce the risk of furniture tipover:**

- ALWAYS install anti-tip device provided.
- NEVER put a TV on this product.
- NEVER allow children to stand, climb or hang on any drawers, doors or shelves.
- NEVER open more than one drawer at a time.
- DO NOT defeat or remove the drawer interlock system; it is an important stability and safety system.
- Place heaviest items in the lowest drawers.

DO NOT remove the interlock system except for maintenance as shown. NEVER use the unit without the interlock installed following the instructions.

The snapper arm must be angled forward in the locked positions to engage the interlock system after removing a drawer. See diagram below.

Close up view of locked snapper

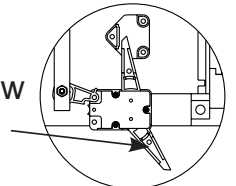

Even if the furniture does not require tipping restraints, it's important these guidelines are followed to prevent injuries.