

Model #

# 3499a

## McKenzie

# Cocktail Table

**GAC = Glazed Antique Cherry finish**

**JAV = Java finish**

**PEC = Pecan finish**

*Assembly Instructions*

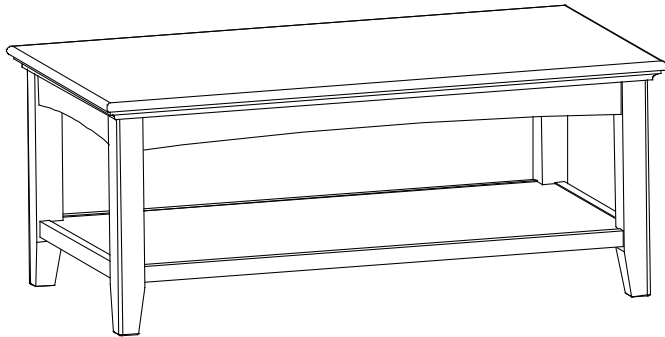

*Thank you for allowing us to help you furnish your home. We are certain you will be delighted with your new furniture for many years to come.*

### IMPORTANT NOTES:

- For normal household use only. *Not* recommended for commercial use.
- Do not climb, sit or stand on this piece of furniture.
- Unload items before you move this unit.
- Do not overload the shelf.

### WARNING

Drilling, sawing, sanding or machining wood products can expose you to wood dust, a substance known to the state of California to cause cancer. Avoid inhaling wood dust or use a dust mask or other safeguards for personal protection.

For more information go to: [www.p65warnings.ca.gov/wood](http://www.p65warnings.ca.gov/wood)

This product can expose you to chemicals, including formaldehyde, which are known to the State of California to cause cancer.

For more information go to: [www.p65warnings.ca.gov/furniture](http://www.p65warnings.ca.gov/furniture)

**DESIGN SUBJECT TO CHANGE WITHOUT NOTICE.**

### CUSTOMER SERVICE

If you ever have questions about your furniture, please do not hesitate to contact us. In the unlikely event you need a replacement part; we can make those parts available through an authorized Whittier Wood Furniture dealer. If you cannot order replacement parts through your dealer, please contact our customer service department.

**Hours:** Our friendly customer service staff can be reached:

**Monday-Friday 8:00 a.m. to 5:00 p.m. (Pacific Time).**

You may leave a message 24 hours a day, seven days a week.

**Customer Service:** 800-653-3336 • **Outside the U.S.:** 541-687-0213

**Fax:** 541-687-2060 • **Email:** [info@whittierwood.com](mailto:info@whittierwood.com)

**Whittier  
Wood**  
FURNITURE

P.O. Box 2827  
Eugene, OR 97402 USA

Production Code :









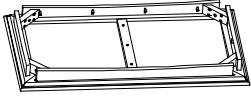

VN

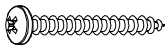
10/23

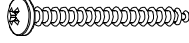
## 3499a McKenZie Cocktail Table

### Parts List

Please identify the parts and check that quantities received match those on this list.  
If you need to replace a part, refer to the following letter and part name.

Part	Description		Quantity
A	Top Assembly		1
B	Leg		4
C	Shelf Assembly		1
D	#8 x 1-1/4" Pan Head Screw		41 (33 inserted)
E	5/16" Flat Washer		4
F	3/8" x 2-1/2" Hex Bolt		4
G	#8 x 1-3/4" Pan Head Screw (inserted)		14
H	3/8" x 1" Insert Nut (inserted)		4
K	Wood Dowel (inserted)		4
L	1/4" x 20mm Insert Nut (inserted)		4
M	Slotted Leveler (installed)		4
N	Leveler Adjustment Key (attached to Owners Manual)		1

# 3499a McKenzie Cocktail Table

## Assembly Instructions

**Tools Required: Phillips Screwdriver, 9/16" or Adjustable Wrench**

**Tool Provided: Leveler Adjustment Key in the Zip bag taped to the Owner's Manual and Safety Guide.**

1. Turn the Top Assembly (A) upside-down on a clean, protected surface. Place two Legs (B) at the back of the Top Assembly (A), making sure the drilled corners of the legs face toward the Corner Blocks. Attach with 5/16" Flat Washers (E) and 3/8" x 2-1/2" Hex Bolts (F). See Figures 1 and 1a.

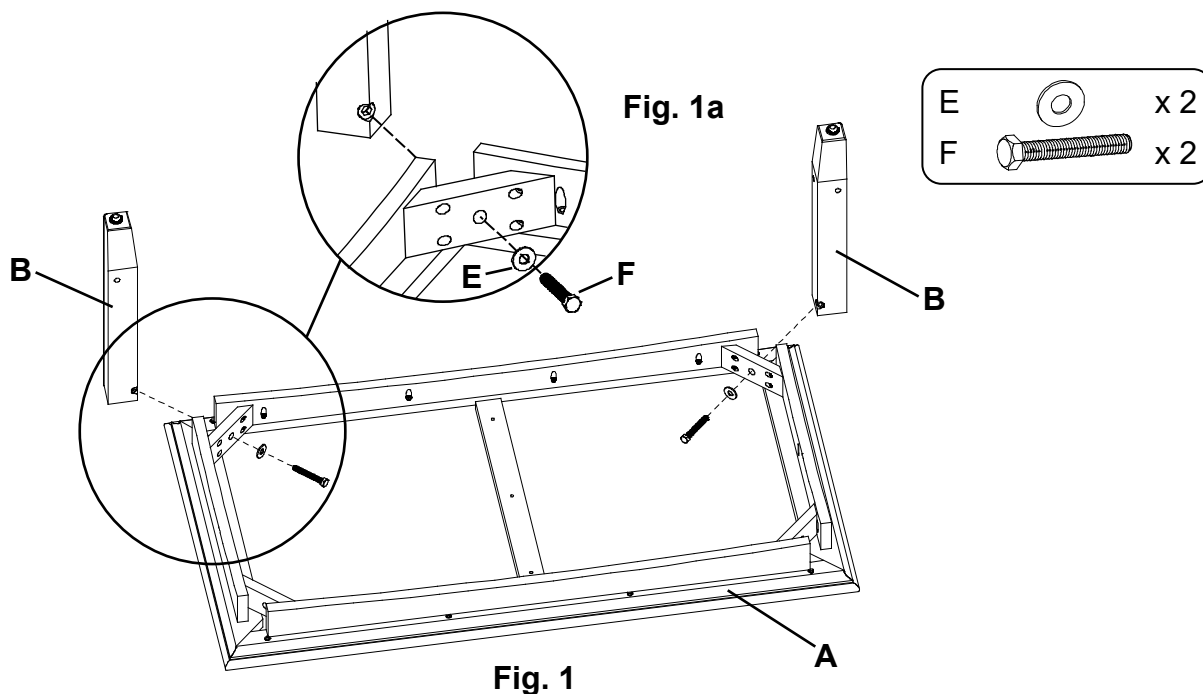

2. Rotate the Top and Leg assembly so that it sets on the back legs. Turn the Shelf Assembly (C) bottom-side-down and place the dowels into the dowel holes in the Legs. See Figure 2.

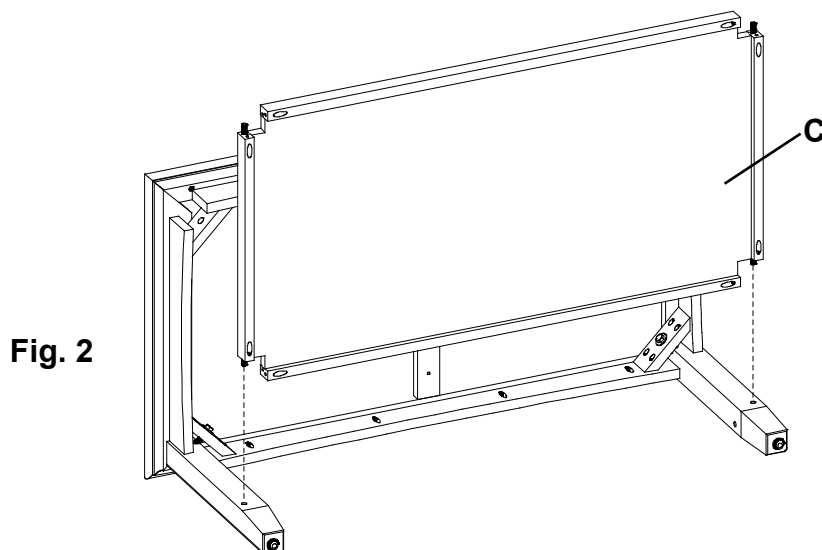

# 3499a McKenzie Cocktail Table

## Assembly Instructions

3. Using the dowels as guides, place the remaining Legs (B) in the remaining two corners making sure the drilled corners of the Legs face toward the Corner Blocks. See Figure 3.

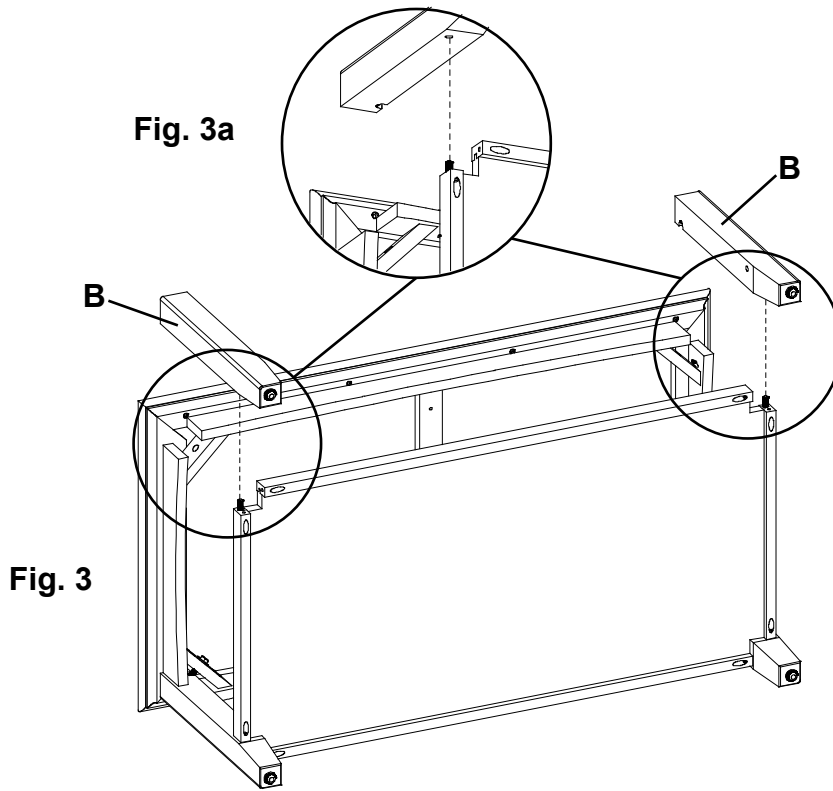

4. Attach the legs to the Top Assembly with 5/16" Flat Washers (E) and 3/8" x 2-1/2" Hex Bolts (F) See Figures 4 and 4a.

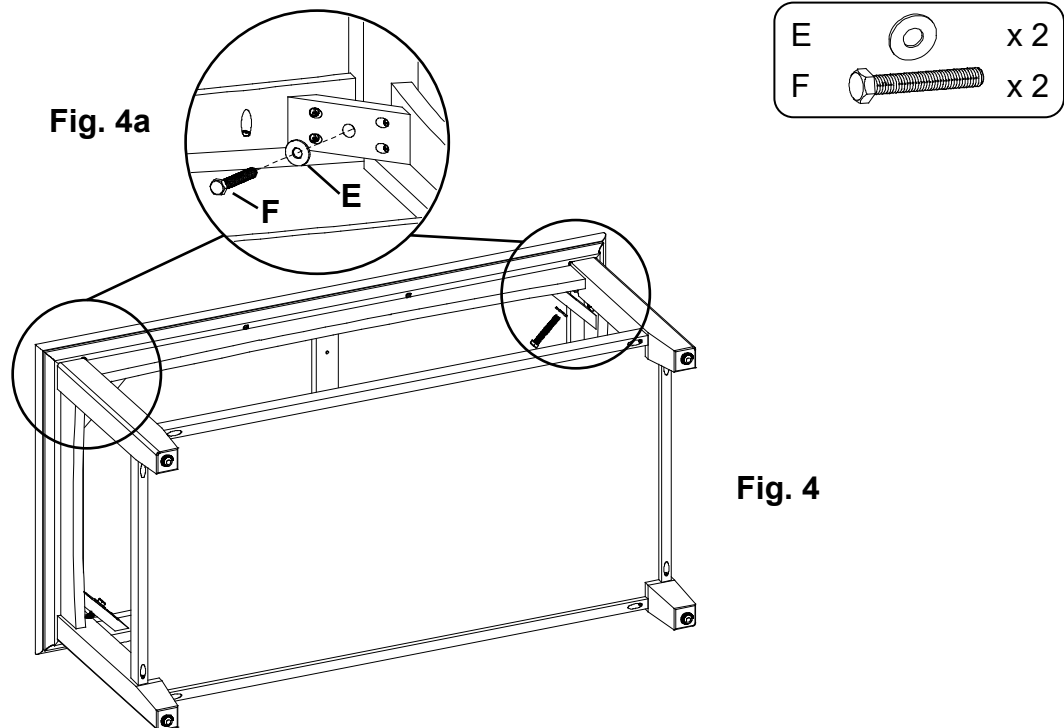

# 3499a McKenzie Cocktail Table

## Assembly Instructions

5. Turn the unit onto its top and using the pocket holes as guides, secure the Shelf Assembly (C) to the Legs (B) with eight #8 x 1-1/4" Pan Head Screws (D). See Figures 5 and 5a.

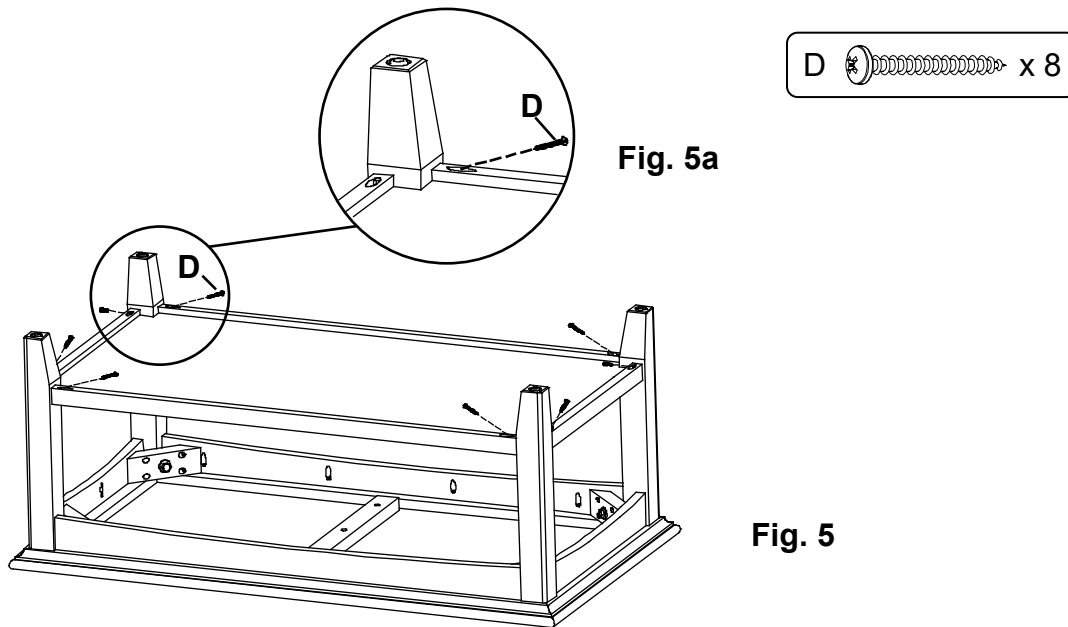

6. Turn the table upright and place at its final destination. Use the Leveler Adjustment Key (N), found in the Zip bag taped to the Owner's Manual and Safety Guide to rotate the Slotted Levelers (M) on the bottoms of the legs until the desk is level. See Figures 6 and 6a.

